

INSTALLATION AND MAINTENANCE INSTRUCTIONS FOR LEGEND® LIGHTBAR

SAFETY MESSAGE TO INSTALLERS OF FEDERAL SIGNAL LIGHT SYSTEMS



People's lives depend on your safe installation of our products. It is important to read, understand and follow all instructions shipped with the products. In addition, listed below are some other important safety instructions and precautions you should follow:

- To properly install a light assembly: you must have a good understanding of automotive electrical procedures and systems, along with proficiency in the installation and use of safety warning equipment.
- When installing equipment or wiring inside air bag equipped vehicles, the installer **MUST** ensure that the equipment or wiring is installed **ONLY** in areas recommended by the vehicle manufacturer. Failure to observe this warning will reduce the effectiveness of the air bag, damage the air bag, or potentially damage or dislodge the equipment, causing serious injury or death to you or others.
- When drilling into a vehicle structure, be sure that both sides of the surface are clear of anything that could be damaged.
- A light system is a high current device. In order for it to function properly, a separate ground connection must be made. If practical, it should be connected to the negative battery terminal. At a minimum, it may be attached to a solid metal body or chassis part that will provide an effective ground path as long as the light system is to be used.
- Locate light system controls so the **VEHICLE** and **CONTROLS** can be operated safely under all driving conditions.
- This product contains high intensity LED devices. To prevent eye damage, **DO NOT** stare into the light beam at close range.
- You should frequently inspect the light system to ensure that it is operating properly and that it is securely attached to the vehicle.
- File these instructions in a safe place and refer to them when maintaining and/or reinstalling the product.

Failure to follow all safety precautions and instructions may result in property damage, serious injury, or death to you or others.

I. GENERAL.

The Legend is a single level LED lightbar, employing ROC "Big Board" technology and Solaris S2 reflectors. The bar operates at a nominal input of 13.6VDC (11 VDC minimum). The basic light functions of the unit are controlled via the CAT5 serial communication cable. The cable connects to either a compatible Federal Signal Serial control head, or, a Federal Signal Serial Interface Module, 8583446. An internal PCB assembly, within the light bar, decodes the control data and performs the requested function. With the interface box, the bar may be activated by Federal Signal lightbar controllers, Signalmaster controllers, and/or individual low current switches. The backbone is an aluminum extrusion and the bases and tops are molded polycarbonate. The bars have twenty-one-foot power and ground cables, and a twenty-five-foot serial cable. Mounting hardware is a Configured option. Refer to mounting instructions supplied with mounting hardware. The bars have an operating temperature range of -30°C to +65°C.

II. UNPACKING.

After unpacking the Legend light assembly, inspect it for damage that may have occurred in transit. If the unit has been damaged, do not attempt to install or operate it. File a claim immediately with the carrier, stating the extent of damage. Carefully check all envelopes, shipping labels, and tags before removing or destroying them.

III. INSTALLATION.



Improper warning system and/or two-way radio system operation may result if a two-way Radio antenna installed on, or within 18-inches of, the lightbar. Before permanent installation of the lightbar or a two-way radio antenna, test the warning system and two-way radio system. DO NOT install a two-way radio antenna on the lightbar.

Some installations may require relocation of the two-way radio antenna to a trunk or fender location.

Warning system failure may result if additional holes are drilled in the lightbar, or if auxiliary devices are installed on the lightbar. DO NOT drill additional holes in the lightbar, or install auxiliary devices on the lightbar.

NOTE

If the internal SignalMaster option will be used, the lightbar should be configured prior to mechanical mounting. Refer to paragraph G, SignalMaster Controls.

A. General.

Before proceeding, ensure that the lightbar has been installed on the vehicle roof in accordance with the instructions packed with the mounting kit.

The lightbar is completely wired at the factory and does not require any additional internal wiring; two 10 AWG power conductors (red and black) and the CAT5 communication cable exit the lightbar. All the conductors necessary for control of any and all basic and optional functions are contained in the CAT5 cable. The basic light functions of the unit are communicated via the CAT5 cable. The cable connects to either a compatible Federal Signal Serial control head, or, a Federal Signal Serial Interface Module.



Light system controls must be located so that the VEHICLE and CONTROLS can be operated safely under all driving conditions.

B. See figure 1. Ensure that the lines are adequately fused as shown. From the lightbar, route the CAT5 control cable into the vehicle's cab or trunk near the eventual location of the compatible Federal Signal Serial control head or FSC #8583446 Interface Module. An input cable is also provided with the FSC #8583446 Serial Interface Module.



Reverse polarity may damage the lightbar and prevent operation. Ensure that correct polarity is observed. Unit must be fused at the source.

C. Route and connect the separate 10 gauge black lead to the vehicle battery ground (-) terminal.

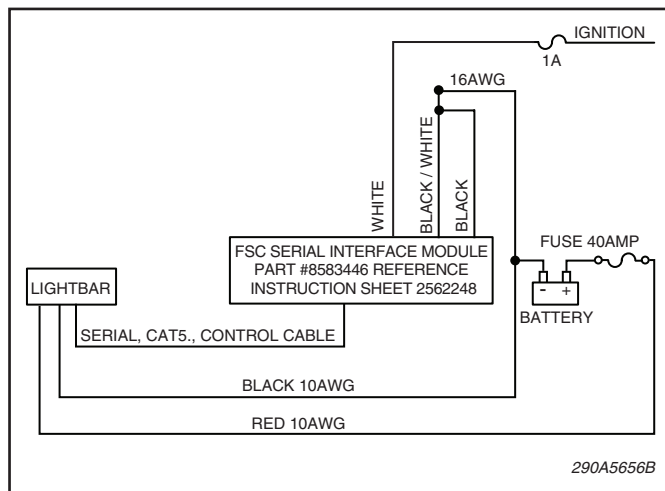

Figure 1.

D. Route and connect the 10 gauge red lead, through the supplied 40A fuse, fused at the source, to the BAT+ terminal.

E. SignalMaster Option.

The SignalMaster function is completely configured at the factory and does not require any additional wiring inside the light bar. All conductors necessary for control of the SignalMaster is via the compatible Serial communication control head or the FSC #8583446 Serial Interface Module. For wiring and operation instructions, refer to the instruction sheet packed with the applicable control head or the FSC Serial Interface Module's Instruction sheet (part number 2562248). The lightbar's SignalMaster operation is factory configured for use with a Federal Signal SignalMaster controller or SS2000SM series siren (EXTERNAL configuration).

F. Light Bar Controls.

The Legend S2 functions are communicated via the CAT5 serial cable. Both the Federal Signal Serial Control Head and the Serial Interface Module are capable of providing the following controls to the lightbar. For programming options, refer to the Installation Manual shipped with the Interface Module or the Federal Signal Serial Control Head.

1. MODE 1 -
2. MODE 2 – overrides MODE 1;
3. MODE 3 – Overrides MODES 1&2;
4. STEADY BURN RED
5. FRONT CUTOFF
6. REAR CUTOFF
7. INTERSECTION
8. FLASH HALOGEN
9. LEFT ALLEY
10. RIGHT ALLEY
11. TAKEDOWN
12. LOW POWER
13. LIGHT BAR TEST PATTERN

G. SignalMaster Controls (INTERNAL configuration).

To configure the lightbar for INTERNAL SignalMaster operation, see figure 2 and refer to paragraph V.6.a, PCB Controller replacement. Move the jumper from the "E" position to the "I" position.

The following patterns are accessible with INTERNAL configuration:

1. LEFT
2. CENTER
3. RIGHT
4. WARN 1
5. WARN 2
6. WARN 3
7. WARN 4
8. FAST

H. Typical Installations.

For typical installations with common control systems, see installation wiring diagrams 1, 2, 3, and 4 at the end of this document.

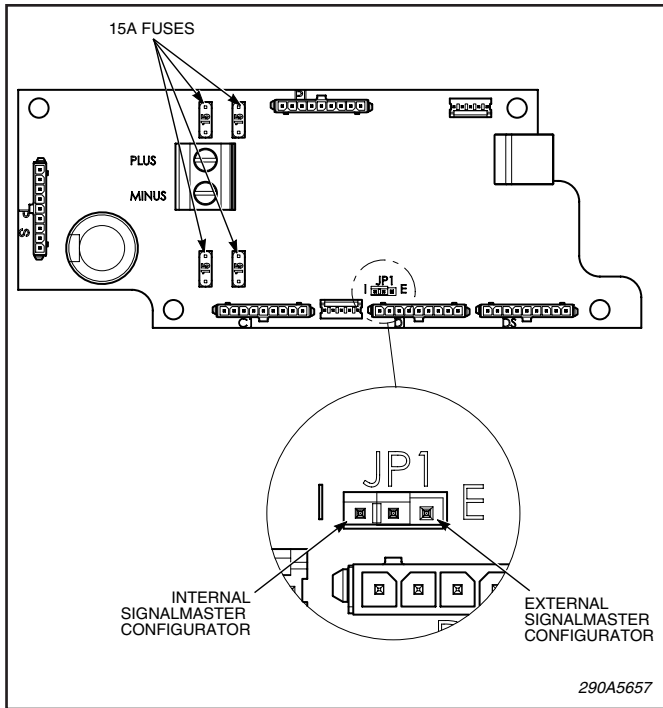

Figure 2.

IV. OPERATION.



This product contains high output LED devices. To prevent permanent eye damage, do not stare into the light beam at close range.

NOTE

Applying 12VDC to the appropriate control line and ignition wire on the Serial Interface Module can activate all the lightbar functions. The 10 gauge black and red power leads must be connected to their respective battery terminals for a function check.

After installation, check the entire system to be sure the lights are flashing properly and all light system functions are operating properly.

SAFETY MESSAGE TO OPERATORS



People's lives depend on your safe use of our products.

Listed below are some important safety instructions and precautions you should follow:

- Although your warning system is operating properly, it may not be completely effective. People may not see or heed your warning signal. You must recognize this fact and continue driving cautiously.
- Also, situations may occur which obstruct your warning signal when natural or manmade objects are between your vehicle and others, such as: raising your hood or trunk lid. If these situations occur, be especially careful.
- This product contains high intensity LED devices. To prevent permanent eye damage, DO NOT stare into the light beam at close range.
- At the start of your shift, you should ensure that the light is securely attached and operating properly.

Failure to follow these safety precautions may result in property damage, serious injury, or death to you, to passengers, or to others.

RETAIN AND REFER TO THIS MESSAGE

V. MAINTENANCE.



Crazing (cracking) of lenses will cause reduced effectiveness of the light. Do not use cleaning agents (which will cause crazing) such as strong detergents, solvents, or petroleum products. If crazing of lenses does occur, reliability of light for emergency signaling purposes may be reduced until lenses are replaced.



After prolonged operation, the unit gets hot and can cause burns. Do not touch the unit while or shortly after it has been operating. Always allow the unit to cool before handling.

A. *General.*

Ordinary cleaning of the plastic lenses can be accomplished by using mild soap and a soft rag. Should fine scratches or a haze appear on a lens, they can best be removed with a specialty plastic cleaner/polish such as Plexus® and a soft cloth. Alternatively, non-abrasive, high quality, one-step, automotive paste cleaner/wax may be used.

B. *Top Removal (see figure 3).*



Do not overtighten nuts.

Remove the Phillips head barrel nuts then carefully remove the top to avoid damaging the lip seal. Verify that an o-ring is under the head of each

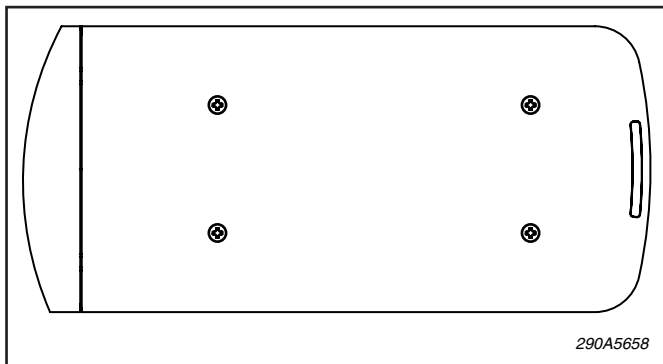

Figure 3.

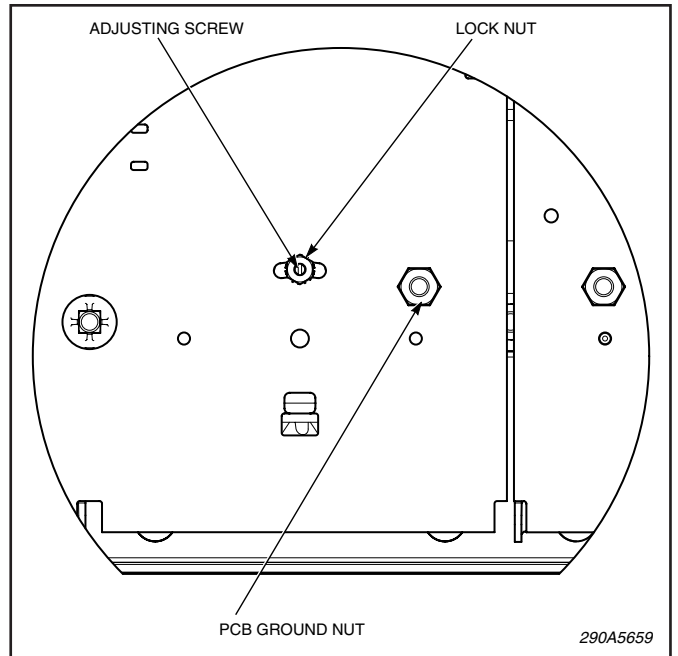

Figure 4.

barrel nut and not stuck to the top. If necessary, use a wooden or plastic pick to remove the o-ring from the top to prevent tearing the o-ring. Inspect lip seal (on base) and o-rings to insure they are not torn, brittle, or damaged. Replace if necessary (see replacement parts). To prevent cross-threading on reassembly, back the barrel nut counterclockwise until an audible click of the threads engaging is heard, then tighten normally.

C. *Halogen Lamp Adjustment (see figure 4).*



Do not overtighten screws/nuts.

Remove the top per paragraph V.B. above. The halogen lamps are adjustable horizontally +/- 8 degrees and vertically +2 degrees/-5 degrees.

- a. Horizontal adjustment: Loosen the lock nut with a 3/8" wrench while holding the adjusting screw with a small screwdriver. Move lamp aim to desired position, then carefully tighten locknut with the wrench while holding adjusting screw with screwdriver.
- b. Vertical adjustment: Loosen the lock nut with a 3/8" wrench while holding the adjusting screw with a small screwdriver. Turn adjusting screw clockwise to lower point of aim, counter-clockwise to raise point of aim. Once positioned, carefully tighten locknut with wrench while holding adjusting screw with screwdriver.

D. Halogen Lamp Replacement.

⚠ WARNING

A serious injury may result if the lamp is touched when hot. Always allow lamp to cool before removing. Halogen lamps are pressurized and if broken can result in flying glass. Always wear gloves and eye protection when handling lamps.

⚠ CAUTION

Service life of the lamp will be shortened if the glass portion is touched. If the glass has been handled, clean carefully with a grease solvent.

a. Takedown lamps: See figures 4 and 5. Remove top per paragraph V.B. Remove PCB ground nut, then invert PCB to access lamp. See the replacement parts list and replace the defective lamp with an exact replacement only. Assemble in reverse order. Do not overtighten nuts.

b. Alley lamps: See figures 4 and 6. Remove top per paragraph V.B. Remove PCB ground nut, then invert PCB to access lamp. With a 1/16" hex key, remove the lamp retaining screws and clamps. Slide lamp and socket from housing just far enough to grasp socket (it may be necessary to unplug connector to gain adequate slack in leads). Holding socket firmly, unplug lamp. See the replacement parts and replace the defective lamp with an exact replacement only. Assemble in reverse order. Do not overtighten screws and nuts.

E. Cleaning Reflector Assemblies.

Use a soft tissue to clean reflectors. Avoid heavy pressure and the use of caustic, abrasive, or petroleum-base cleaners, which will scratch or dull the surface.

F. PCB Controller Replacement (see figure 7) and Halogen / LED Head Fuse Access.

1. Remove the passenger side end dome per paragraph V.B., remove the PCB ground nut from the end PCB, and invert PCB, noting ground lead placement on ground bracket.

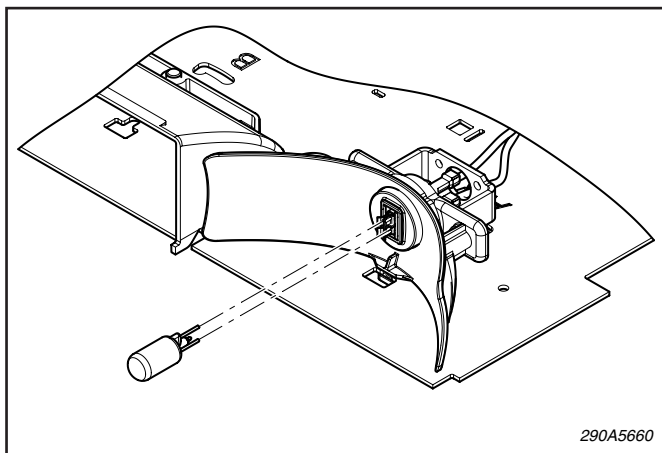

Figure 5.

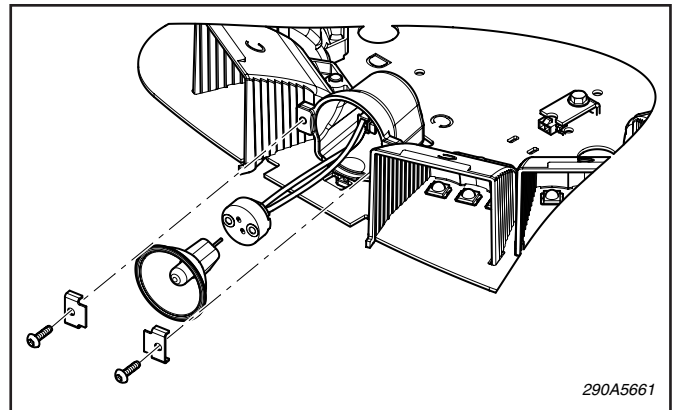

Figure 6.

2. Note and record connections, then disconnect wires and harnesses.

3. Compress the lock tab on the nylon standoffs and remove controller with standoffs from main PCB.

4. Compress secondary lock tabs and remove standoffs from controller.

5. Assembly is the reverse of disassembly. Ensure ground leads are in place. Do not overtighten nuts.

G. PCB Replacement (see figures 4 and 7).

1. Remove dome per paragraph V.B., remove the PCB ground nut, and invert PCB.

2. Note and record connections, then disconnect wires and harnesses.

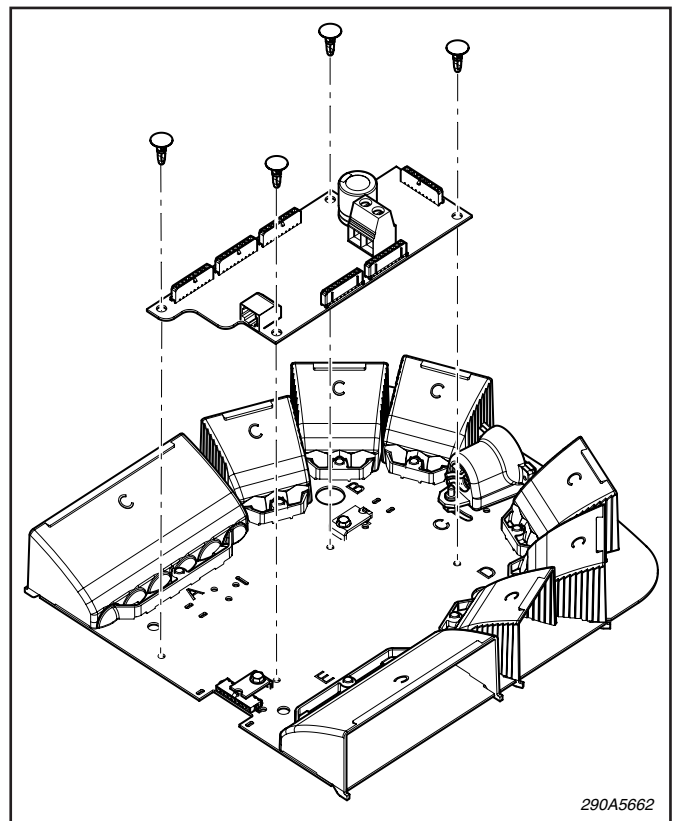

Figure 7.

3. If required, remove controller per paragraph V.F.3.

4. Assembly is the reverse of disassembly. Ensure ground leads are in place. Do not overtighten nuts.

H. *Fuse Replacement (see figure 2).*

Four 15A fuses are on the PCB Controller. Access the fuses per paragraph V.G.1.

I. *Base Replacement (see figure 8).*

1. Remove top per paragraph V.B., and PCBs per paragraph V.G.1. and V.G.2.

2. Remove ground bracket nut, ground bracket with lockwasher, base retainer screw, and (cable entry side only) cable hold down clamp.

3. If the bar is on the vehicle: Slide base from extrusion, catching the carriage bolts as they are freed from the channels.

If the bar is off the vehicle: Invert bar on cloth or cardboard to prevent scratching the tops, then slide base from extrusion. Carriage bolts can then be removed from base.

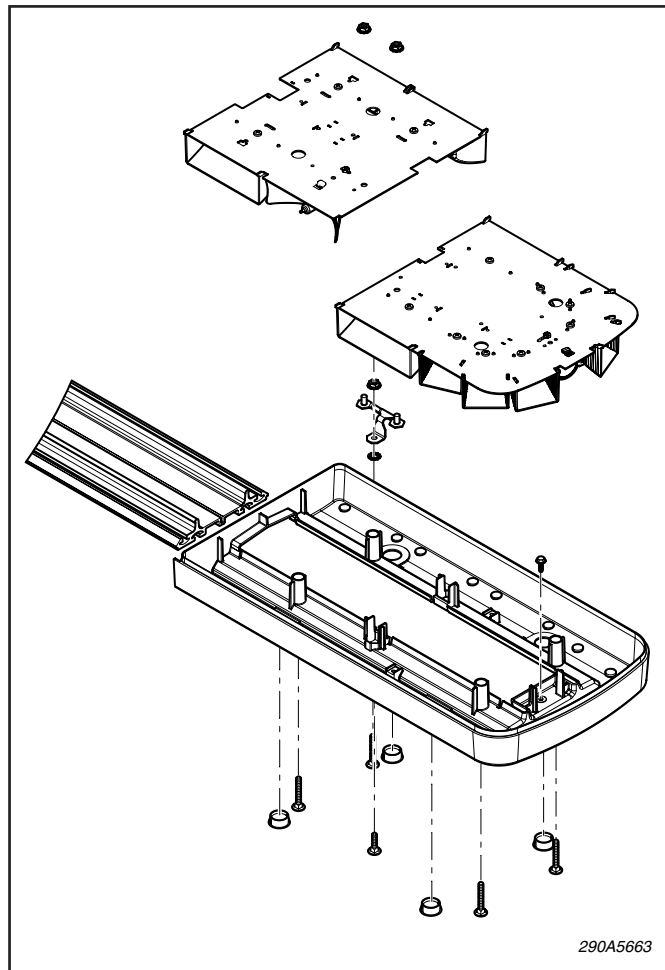

Figure 8.

4. Remove vent plugs and/or grommet from base.

5. Be sure new base has new end gasket and lip seal.

If the bar is on the vehicle, proceed as follows:

Start base onto extrusion, insert the first two carriage bolts (long) into their respective wells, then hold the bolts up while sliding the base further onto the extrusion. If desired, the top barrel nuts may be temporarily installed to hold the bolts in position. Repeat with the ground carriage bolt (short), sliding the base on just far enough to trap the bolt, then repeat with the two remaining long carriage bolts.

If the bar is off the vehicle, proceed as follows:

With the bar still inverted from paragraph V.H.3., start base onto extrusion, then drop the carriage bolts into their respective wells (the ground bolt is the short one). Slide the base onto the extrusion

6. Apply end pressure to base to get a flush fit between the bases before installing base retainer screw. Remaining assembly is the reverse of disassembly. Ensure a star washer goes onto the ground screw prior to installing the ground bracket and that all ground leads are in place. Do not overtighten nuts.

J. *Lip Seal Replacement (see figure 9).*

Remove top per paragraph V.B. Note the joint position of the seal, then remove old lip seal. Install the seal with the fins angled downward as shown, positioning the joint in the same position as original (slightly off-center along the straight surface where the bases mate). The edge of the seal should be flush with the top surface.

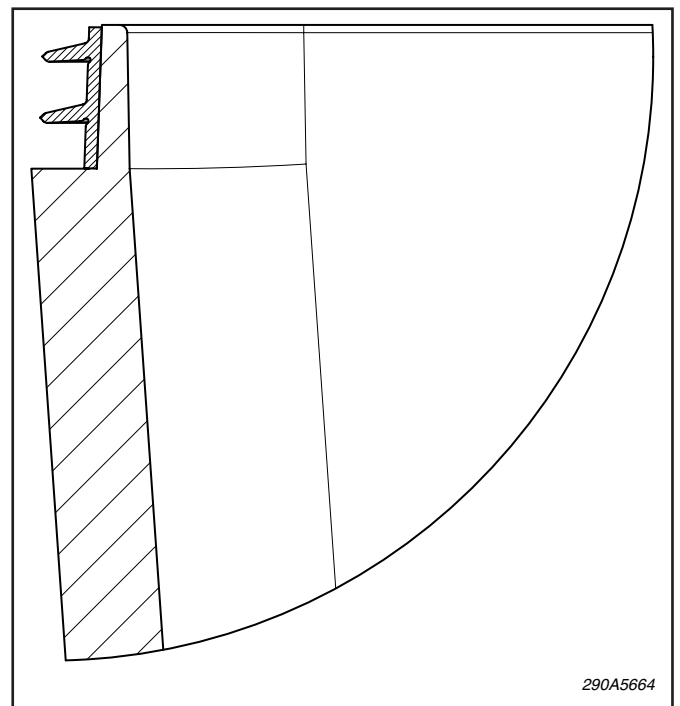

Figure 9.

VI. REPLACEMENT PARTS.

Description	Part No.
PCB Assembly, End (Configured)	Contact Factory
PCB Assembly, Intermediate (Configured)	Contact Factory
PCB Assembly, Center (Configured)	Contact Factory
PCB Assembly, Controller	2005429-1234
PCB Assembly, Controller, Steady Burn Red DS (CA)	2005429-124
PCB Assembly, Controller, Steady Burn Red DS & PS (CA)	2005429-234
Lamp, Halogen Alley, 35W, MR-11	8107241
Lamp, Halogen Takedown, 50W, GH-8 Bi-Pin 8107169	
Fuse, Mini, 15 Amp	148181-06
Fuse, Maxi, 40 Amp	148182-01
Seal, Lip, Clear (5.5ft per end section; 3.5ft per center section)	8583020-01
Gasket, End	8653110
O-Ring, Dome Nut	7067016
Base, End	8653100
Top, End, Clear	8653101
Top, End, Amber	8653101-02
Top, End, Blue	8653101-03
Top, End, Red	8653101-04
Base, Center	8653102
Top, Center, Clear	8653103
Top, Center, Black	8653103-01
Top, Center, Amber	8653103-02
Top, Center, Blue	8653103-03
Top, Center, Red	8653103-04

Manufactured by:
Federal Signal Corporation
Emergency Products Group
2645 Federal Signal Drive
University Park, Illinois 60466
1-800-433-9132

Copyright 2007 Federal Signal Corporation

VII. INSTALLATION WIRING DIAGRAMS.

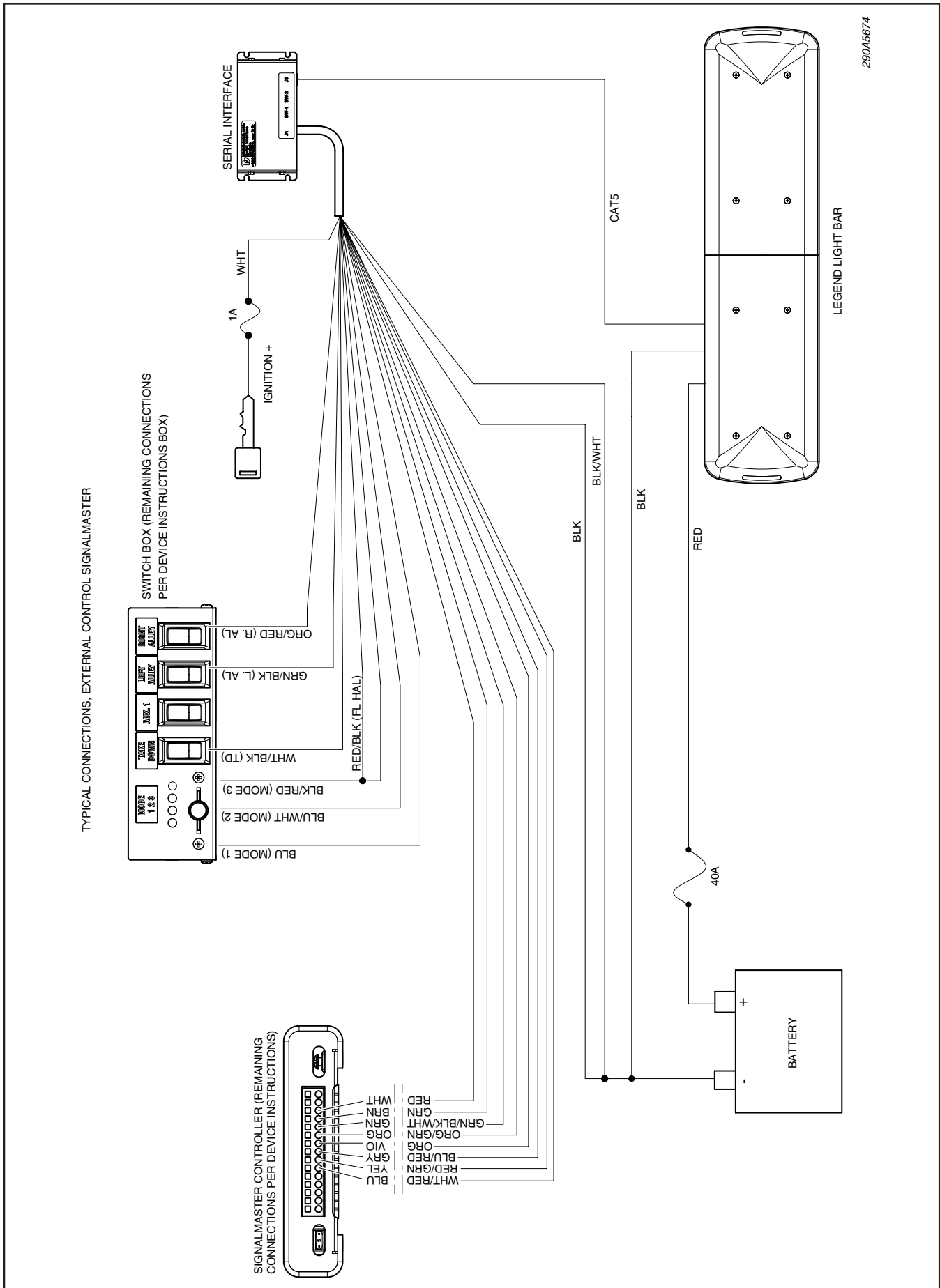

Installation Wiring Diagram 1.

TYPICAL CONNECTIONS, INTERNAL CONTROL SIGNALMASTER

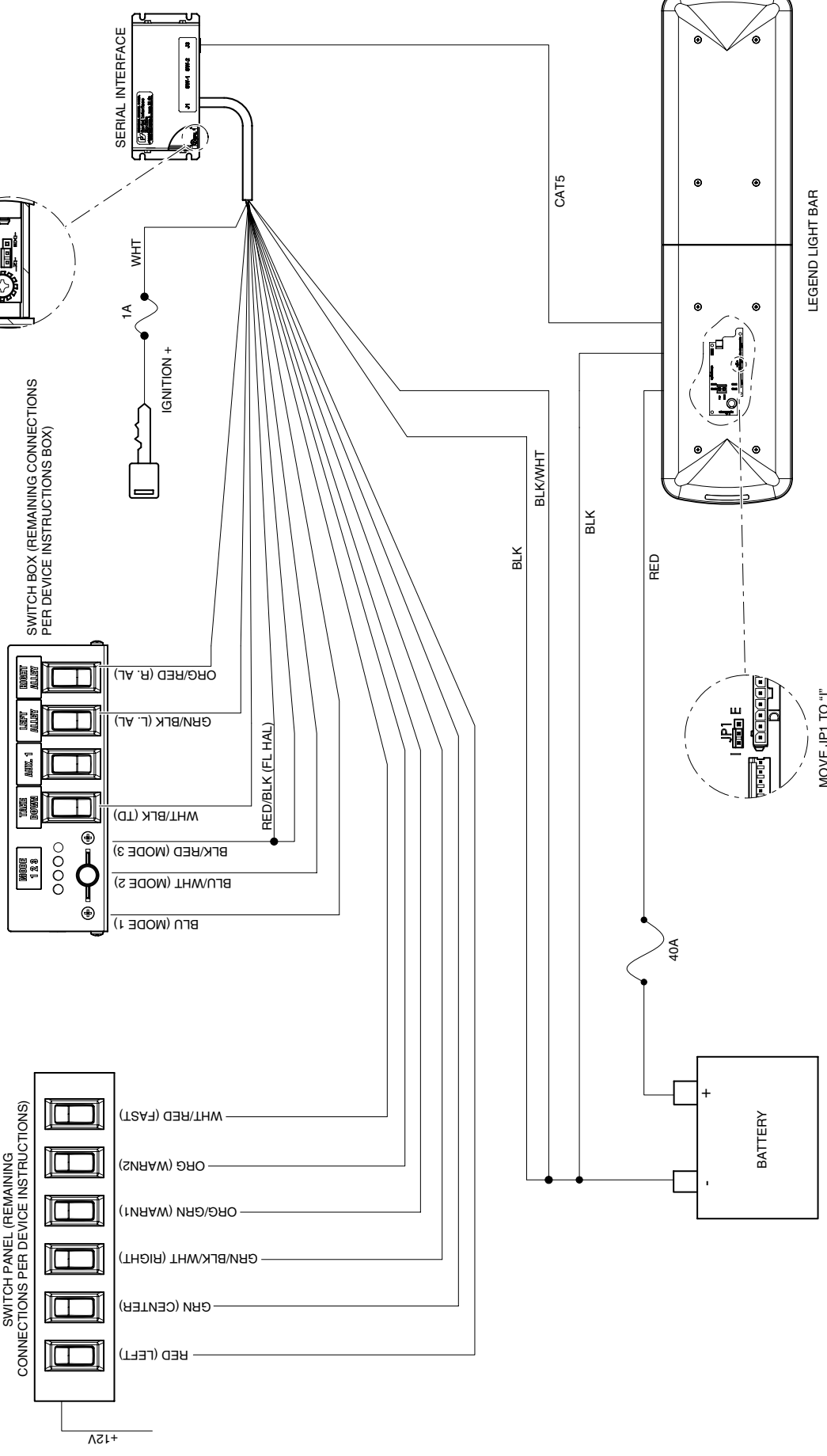

290A5675

Installation Wiring Diagram 2.

TYPICAL CONNECTIONS, SS2000SM

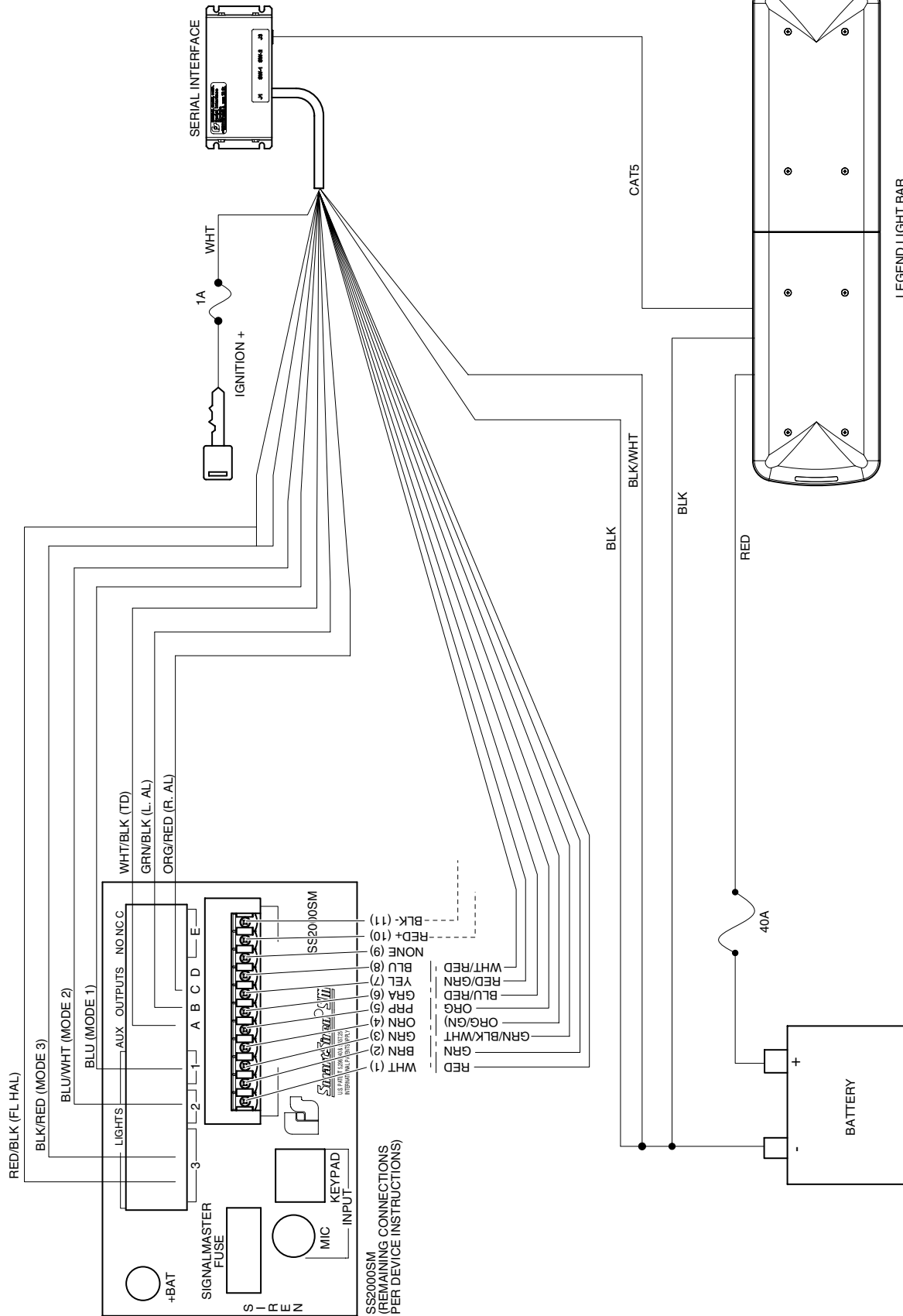

290A5676

Installation Wiring Diagram 3.

TYPICAL CONNECTIONS, NON-SIGNALMASTER

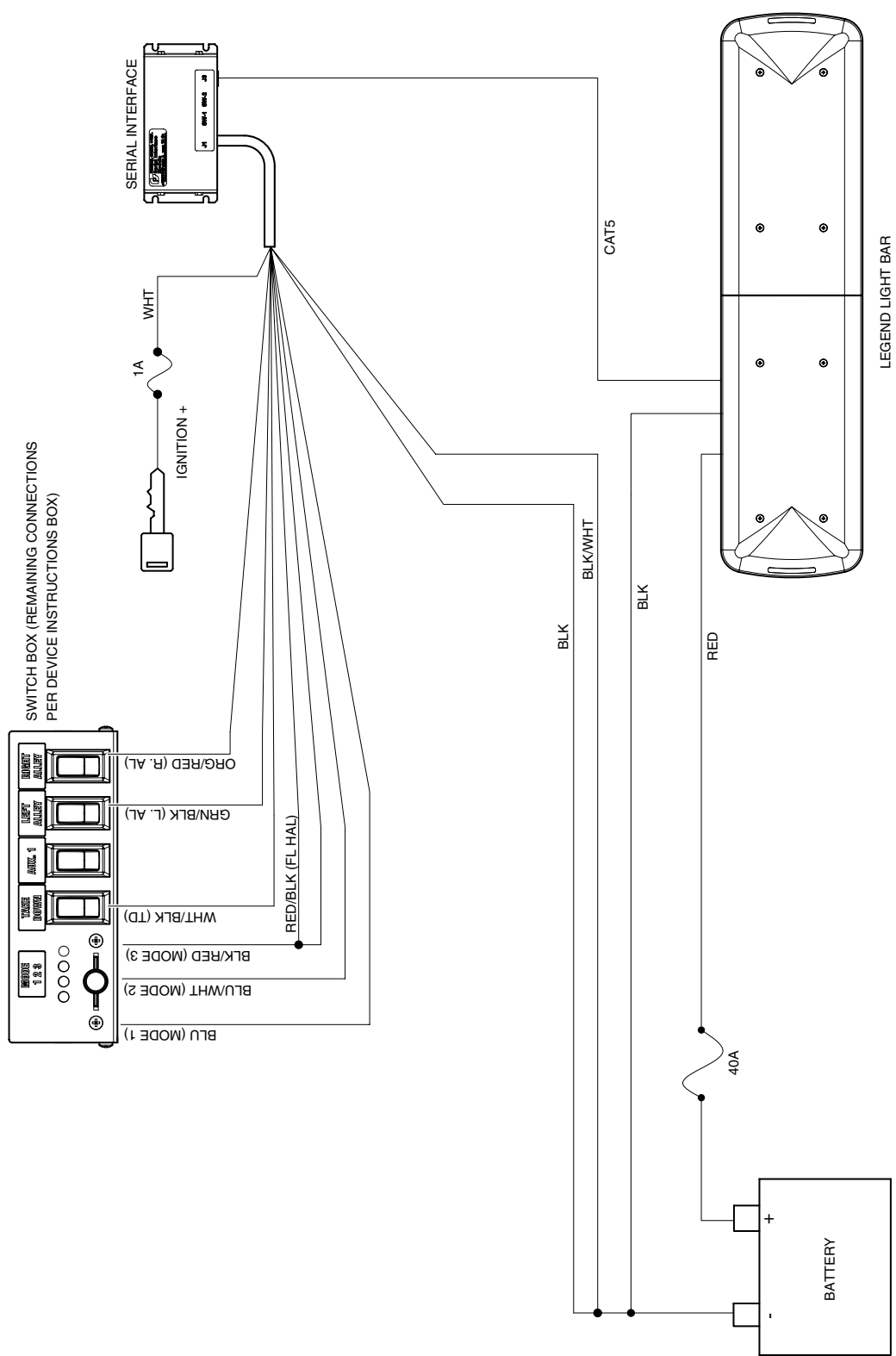

290A5677

Installation Wiring Diagram 4.

