

LE-106CH / LE-106DCH

LUZ DE AVISO ESTROBOSCÓPICA / STROBE WARNING LIGHT

SERVICE

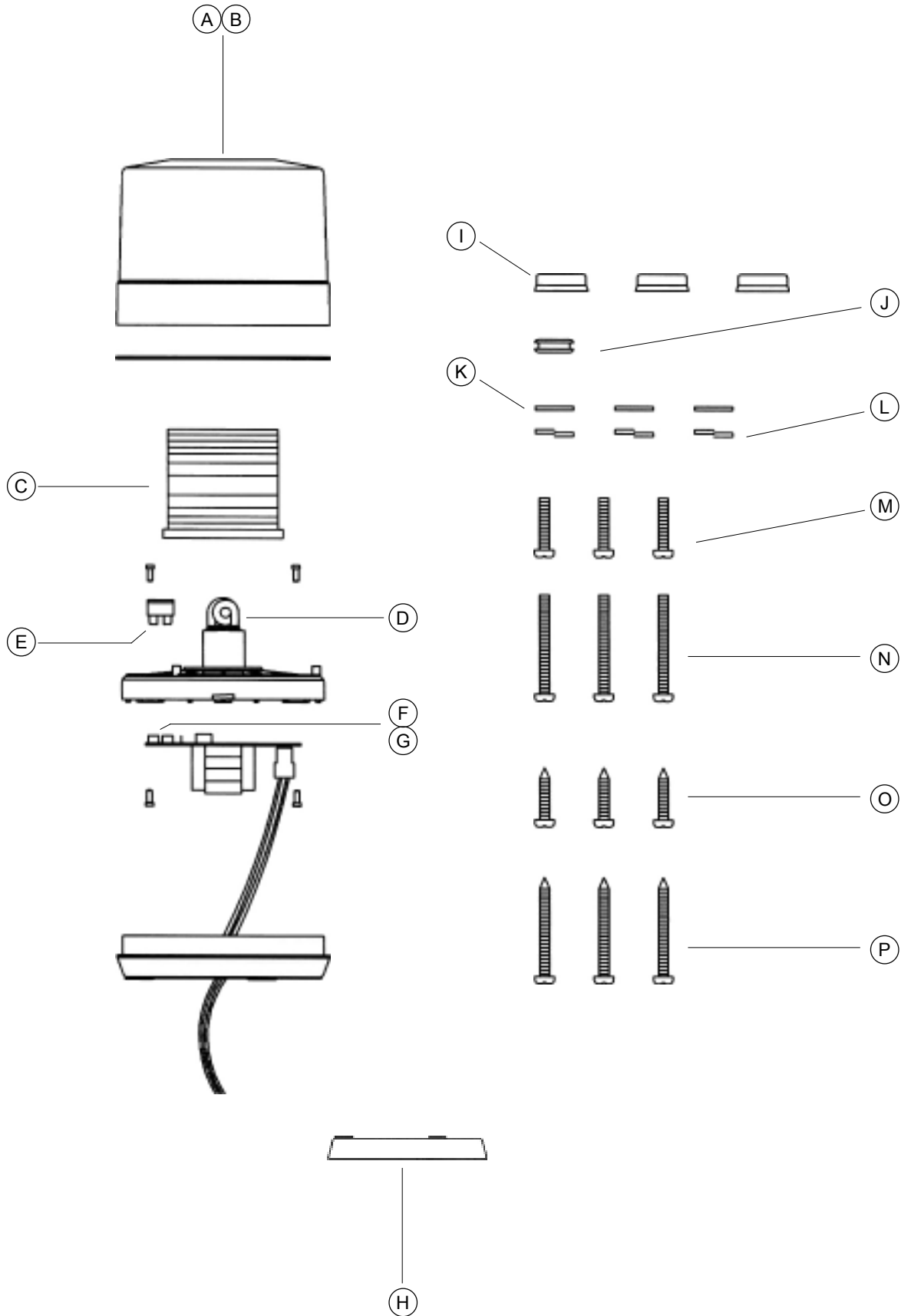

LE-106CH / LE-106DCH

LUZ DE AVISO ESTROBOSCÓPICA / STROBE WARNING LIGHT

Item N.	Descripción / Description	Ref.	Cant. / Qty.
A	Lente d-164x130 azul estroboscópica <i>D-164x130 strobe blue lens</i>	8233328REC	1
B	Lente d-164x130 ámbar estroboscópica <i>D-164x130 strobe amber lens</i>	8233327REC	1
C	Lente Fresnel <i>Fresnel lens</i>	8133271-01	1
D	Conjunto lámpara estroboscópica <i>Strobe tube assembly</i>	8233347REC	1
E	Fusible enchufe universal 40-7,5 A <i>40-7,5 A universal plug fuse</i>	9015101	1
F	Fuente alimentación LE-106CH <i>LE-106CH power supply</i>	8235556REC	1
G	Fuente alimentación LE-106DCH <i>LE-106DCH power supply</i>	8235541REC	1
H	Junta base estroboscópica <i>Strobe base joint</i>	9133924	3
I	Junta retén M-106 <i>M-106 joint</i>	9133850	3
J	Pasacable <i>Grommet</i>	9015032	1
K	Arandela M05x15 DIN9021 <i>DIN9021 M05x15 washer</i>	9027788	3
L	Arandela M05 DIN127 <i>DIN127 M05 washer</i>	9027109	3
M	Tornillo M05x16 DIN7985 <i>DIN7985 M05x16 screw</i>	9027769	3
N	Tornillo M05x30 DIN7985 <i>DIN7985 M05x30 screw</i>	9027770	3
O	Tornillo 4,2x16 DIN7981 <i>DIN7981 4,2x16 screw</i>	9027258	3
P	Tornillo 4,2x32 DIN7981 <i>DIN7981 4,2x32 screw</i>	9027651	3

SERVICE



Empresa certificada ISO / ISO certified Company

FEDERAL SIGNAL VAMA, S.A

Dr. Ferrán, 7 (08339) VILASSAR DE DALT,
BARCELONA, SPAIN

Tel. (00) 93 741 79 42 (Spain)

Tel. (34) 93 741 79 41 (Int.)

Fax (34) 93 753 03 62

email: service@vama.es

Web : www.fedsig.vama.es

Delegación - Madrid

Avda. Baviera, 13

(28028) MADRID

Tel. (34) 91 355 22 00

Fax (34) 91 355 35 61

email: servicemad@vama.es

S11050003-0 09/2002